

Hardware-at-a-Glance

- 200Gbps Lossless Packet Capture
- 16 lane, Gen 3 PCIe (supports all standard motherboards, PCIe bifurcation not required)
- 2-port QSFP28 Optics: SR4 & LR4 (purchased separately)
- External 1 PPS TTL serial input via front panel mini coax

Key Features

- Flow Classification: track up to 32 million unique IP flows
- Flow Shunting: Programmatically forward, drop, or redirect flows (blacklist matching)
- Interconnection of two ANIC-200Kq adapters via direct attached cable (DAC) allows full 200Gbps data transfer across PCIe bus
- Reduced power consumption: 50 watts per adapter
- 4ns precision timestamping
- Linux and FreeBSD drivers

ANIC-200Kq

Dual Port 100G QSFP28 Flow Classification and Shunting Adapter

The ANIC-200Kq is a state-of-the-art, 2-port 100G PCIe adapter/NIC designed for demanding network monitoring and security applications. This FPGA-based adapter features dual 100GbE QSFP28 interfaces supporting SR4 and LR4 optical modules and is designed for NEBS compliance.

The ANIC-200Kq provides sophisticated flow classification and flow shunting capabilities enabling up to 32 million unique (based on 3 or 5-tuple) IP flows to be tracked. Flow shunting enables security features such as blacklist matching by allowing individual flows to be programmatically forwarded to the CPU, dropped or redirected out of either QSFP28 port.

The ANIC-200Kq comes complete with an array of packet processing features such as precise timestamping (4nS precision), packet merging, tunnel decapsulation, packet slicing, packet filtering, deduplication, packet steering, direct memory access (DMA), and more.

For applications requiring full 200Gbps lossless data transfer across the PCIe bus into the host CPU (host packet buffers), two separate ANIC-200Kq adapters can be interconnected via a direct attached cable (DAC). The DAC connection between the ANIC-200Kq adapters enables an aggregate 200Gbps of received traffic to be load balanced between the cards and transferred across the PCIe bus for processing by the CPUs. The two ANIC adapters can be in the same physical appliance or in different appliances as illustrated in the following diagram.

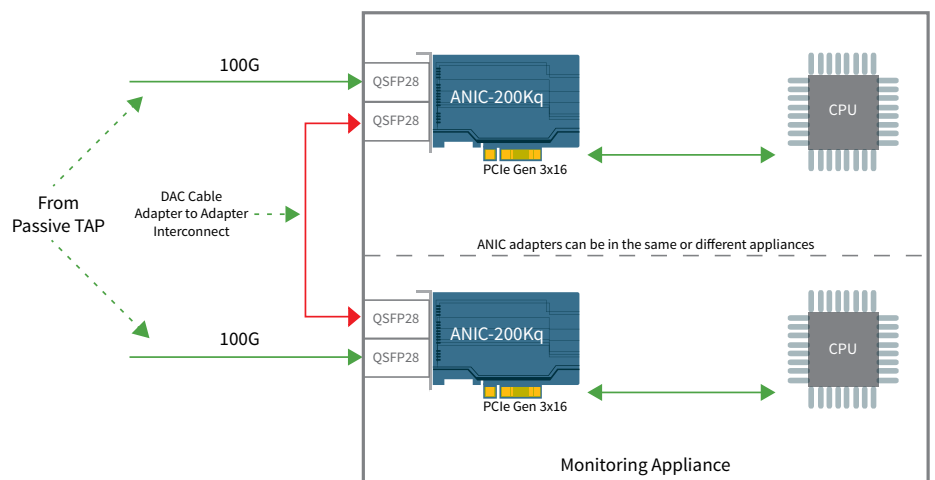

Applications

- Passive and Inline Network Monitoring
- Network Security and Forensics
- In-Line Deep Packet Inspection (DPI)
- Network Test and Measurement
- Network Probes
- Video Stream Monitoring
- High Frequency Trading (HFT)
- Application Performance Monitoring (APM)
- High Performance Computing (HPC)

Software Support

The ANIC-200Kq comes with a software development guide and world class technical support.

A lightweight, C language API is linked to the network monitoring or security application as a shared library. Various API calls are then made to communicate with and control the ANIC-200Kq.

A Linux or FreeBSD device driver is loaded into the network appliance as an extension to the host kernel. As with conventional device drivers the ANIC driver facilitates communication to the ANIC adapter (via the host kernel) for common operations such as adapter setup, turning ports on and off or reading port status.

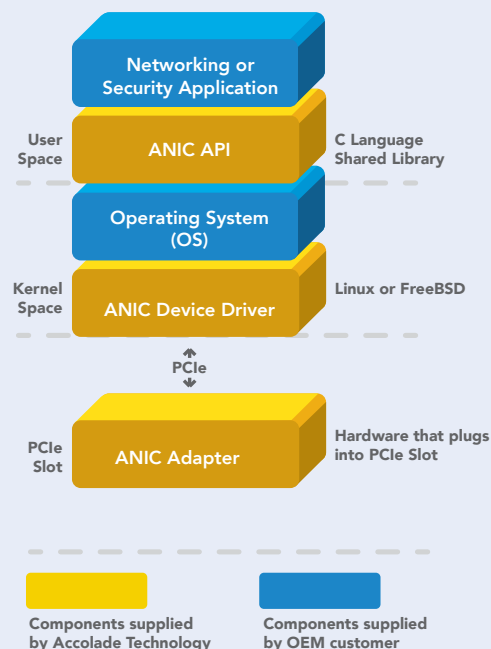

Specifications

Hardware

- PCI Interface: 16 lanes Gen 3 PCI Express
- 100G Connector: QSFP28 per QSFP MSA, 100GBASE-SR4 and 100GBASE-LR4
- Timing Interface: TTL external 1 PPS input via mini-coax and repeater output

Memory

- Packet Memory: 12GB
- Flash Memory: 512MB

Environmental

- Operating Temperature: 0° to 50°C (32° to 122°F)
- Operating Humidity: 0 to 95%, non-condensing

Power

- 50 watts (without optics)
- Each QSFP28 optic adds 3.5 watts

Non-NEBS Dimensions

- 4.25 (H) x 10.5 (L) inches (107 x 266 mm)
- Full Height, 3/4 Length

Designed for NEBS Dimensions

- 4.25 (H) x 12.28 (L) inches (107 x 312 mm)
- Full Height, Full Length

Compliance

- EMI per FCC Part 15/EN 55022/VCCI/AS/NZS Immunity per EN 55024
- Ethernet: IEEE 802.3ba 100GBASE-SR4 & LR4
- NEBS level 3 per GR-63 & GR-1089
- PCI-SIG®, RoHS, REACH

